



**QUICKFOLD**

**MOVABLE  
WALL**



**AVA KONSTRUKT**

**CREATING FLEXIBLE SPACE**



**AVA KONSTRUKT**

## **ABOUT US**

AvaKonstrukt Construction was established in 2020 with the core intention of making the process and supply of finishing building components quicker and more affordable. We are 100% Filipino Owned, creating job opportunities for many Filipino from every craft and expertise in the field, allowing us to combine innovative products. Ava Konstrukt takes on the role of Building Components Contractor for small to large-sized projects and performs Project Management Services to coordinate specialist trades for Industrial, Commercial and Residential Projects.

## **VISION**

We believe in nurturing the skills of our team members and providing growing levels of responsibility. Our People bearing unique skills, energy, expertise, experience and perspectives to our workforce as we want to build the best place to work. We are relentless in keeping people safe from harm and we provide a healthy work environment. We truly desire the best for everyone and engage employees in turn create better project outcomes, stronger client relationships and an exceptional work environment overall.

## **MISSION**

Our mission is to provide the highest-quality workmanship possible. Our aim is to be the first choice for specialized construction-related services and to be an integral part of our clients | partners success. We are committed to best practices and professional integrity to ensure we deliver high-quality products and reliable services. Customer satisfaction drives every aspect of our business.

## **OUR PRODUCTS**

**MOVABLE WALLS  
QUICKFOLD ACCORDION  
TOILET PARTITION  
OFFICE PARTITION  
WINDOW TREATMENTS  
ACOUSTIC TREATMENT PANELS  
WOOD X METAL FURNITURE  
CARPETS & THEATRE SEATS**

### **QUICKFOLD® MOVABLE WALL**

Movable Wall are used extensively in large rooms to partition the space for maximize space utilization, revenue potential and sound control. They are interlocking flat panels that are attached to an overhead track to move and reconfigure. Movable Wall is a system of individual solid or glazed panels that can be moved independently from each other which when fitted together end to end form a continuous flat wall. Movable Wall panels are designed to be easily maneuvered and operated. If your partition needs include proven field performance and durability combined with competitive price point, Ava Konstrukt's QUICKFOLD® MOVABLE WALL is your best option. We provide design assistance to owners, design professionals and contractors to be sure that the right movable wall system is installed in your facility. We listen to your goals and make recommendations to reduce initial and ongoing maintenance cost, to maximize room divider flexibility and control sound transmission. We service all Movable Walls, room dividers and acoustical divider partitions.

**CREATING FLEXIBLE SPACE**



## QUICKFOLD 100

**QUICKFOLD® 100** is critical to the effective use of space in hotels, events places, civic halls, and other commercial facilities. Purpose-made panels can be manufactured to clients' specific requirements, offering total space flexibility, long-lasting use, and high standards of Finishes, sound reduction, and durability. The purpose of this Movable Wall is to serve the same purpose of separating a room in a way that creates a lasting impression about a space. Movable Walls have such a huge impact on the look, feel, and acoustic control in the spaces they divide. If your partition needs include proven field performance and durability combined with a competitive price point, Ava Konstrukt's QUICKFOLD® 100 series is your best option.



## QUICKFOLD 62

**QUICKFOLD® 62** is a top hung movable wall of lighter construction made up of individual panels designed to give lasting use in the division of space requiring flexibility. This series is ideal for use in classrooms, meeting rooms and offices. The purpose of this Movable Wall is to serve the same purpose of separating a room in a way that creates a lasting impression about a space. Panels can be finished in full range of veneers and laminates, fabric, graphite, or any compatible preferred finish to suit clients' requirements.



**CREATING FLEXIBLE SPACE**

# QUICKFOLD 100

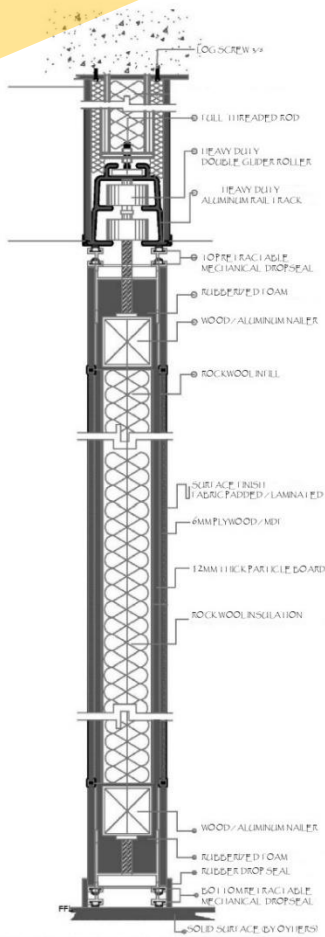

VERTICAL SECTION

## CROSS SECTION OPERABLE DETAILS

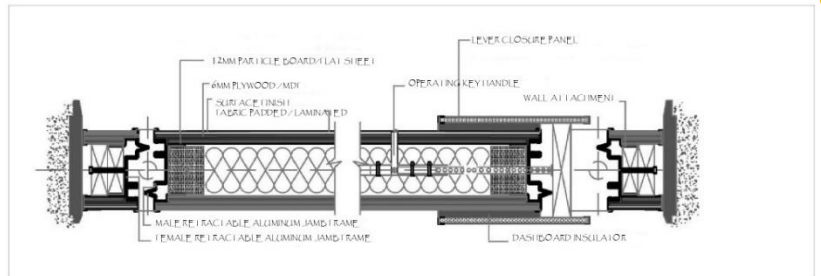
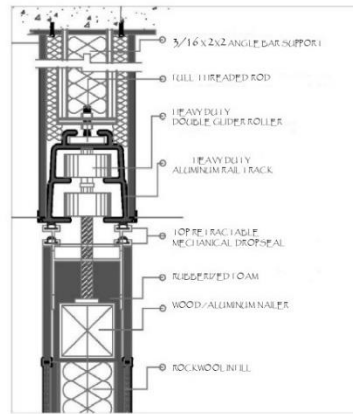

HORIZONTAL SECTION DETAILS

# QUICKFOLD 62

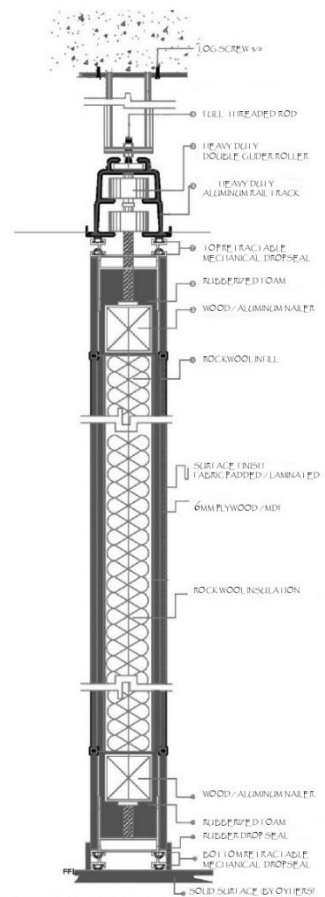

VERTICAL SECTION

## CROSS SECTION OPERABLE DETAILS

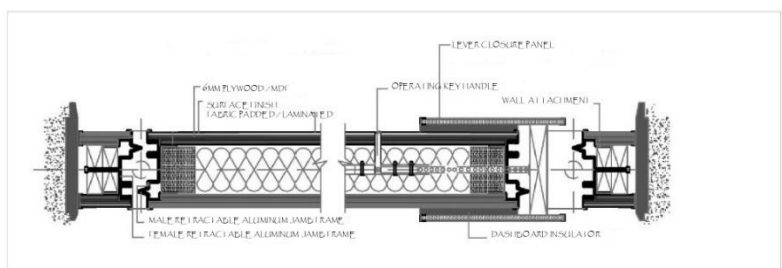
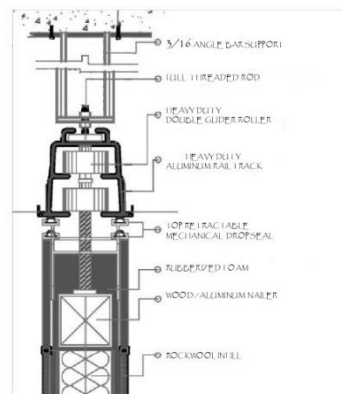

HORIZONTAL SECTION DETAILS

CREATING FLEXIBLE SPACE

**STANDARD PRODUCT SPECIFICATION**

SERIES:	QUICKFOLD 62	QUICKFOLD 100
STC RATING:	28-31 STC	48-51 STC
PANEL THICKNESS:	62MM	100MM
PANEL WIDTH:	1.2M (MAXIMUM)	1.2M (MAXIMUM)
PANEL HEIGHT:	4 METERS (MAXIMUM)	7 METERS (MAXIMUM)
PANEL WEIGHT:	10 KGS / SQM	18 KGS / SQM
FRAME:	EXTRUDED ALUMINUM JAMB	EXTRUDED ALUMINUM JAMB
TRACK:	HEAVY DUTY ALUMINUM	HEAVY DUTY ALUMINUM
ROLLER:	HEAVY DUTY GLIDER 2 WHEEL ROLLER	HEAVY DUTY GLIDER 2 WHEEL ROLLER
SEALS:	TOP AND BOTTOM MANUALLY OPERATED RETRACTABLE INTERLOCKING SEAL	TOP AND BOTTOM MANUALLY OPERATED RETRACTABLE INTERLOCKING SEAL
PANEL FINISH:	FOAM PADDED FABRIC   LAMINATED   MELAMINE   GRAPHICOTE	FOAM PADDED FABRIC   LAMINATED   MELAMINE   GRAPHICOTE
SOUND BARRIER:	NONE	9MM GYPSUM BOARD WITH ROCKWOOL INSULATION
PANELS:	MANUALLY OPERATED INDIVIDUAL PANEL TOP AND BOTTOM SUPPORTED LEVER CLOSURE PANEL WALL ATTACHMENT 60 KG PER CUBIC METER HIGH DENSITY ROCKWOOL INSULATION	MANUALLY OPERATED INDIVIDUAL PANEL TOP AND BOTTOM SUPPORTED LEVER CLOSURE PANEL WALL ATTACHMENT 100 KG PER CUBIC METER HIGH DENSITY ROCKWOOL INSULATION WITH DOUBLE SKIN 12MM THICK PARTICLE BOARD WITH FLAT SHEET FOR ADDED SOUND BARRIER
WARRANTY:	1 YEAR	3 YEARS
OPTION:	PASSDOOR INSET	PASSDOOR INSET

## MOVABLE WALL STACKING CONFIGURATION

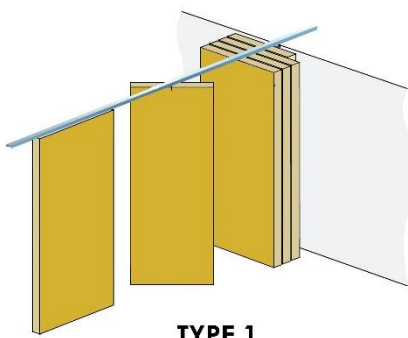

**TYPE 1**

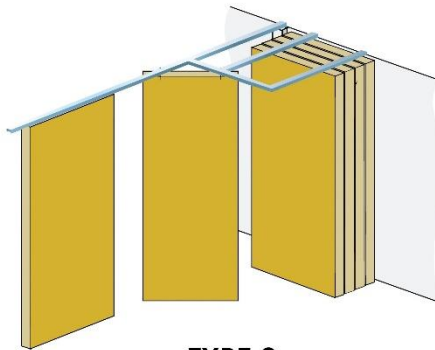

**TYPE 2**

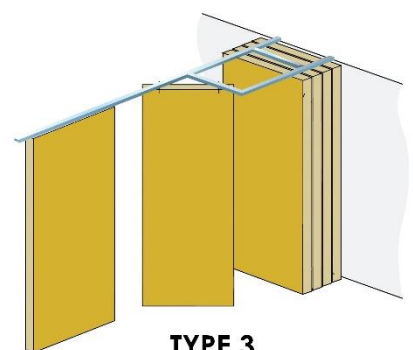

**TYPE 3**

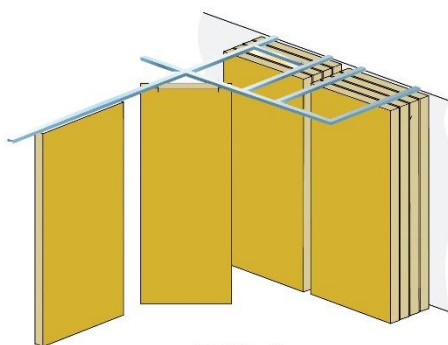

**TYPE 4**

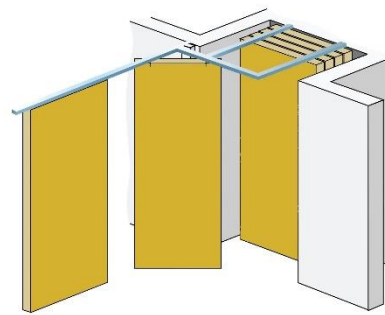

**TYPE 5**

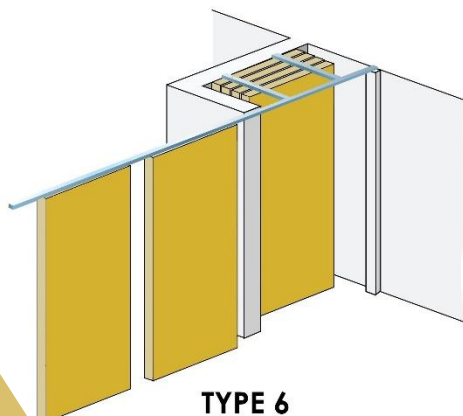

**TYPE 6**

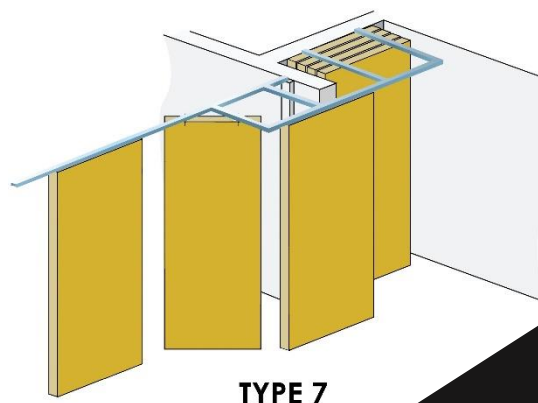

**TYPE 7**



CARPETS



TOILET PARTITION



ACOUSTIC TREATMENT PANELS



WINDOW TREATMENTS

## OTHER PRODUCTS



WOOD X METAL FURNITURE



QUICKFOLD ACCORDION



THEATRE SEATS



AVA KONSTRUKT



+632 8642 0130



+63 9499982001 | +63 9155134432



info@avakonstrukt.com



www.avakonstrukt.com



Unit G 2<sup>nd</sup> Flr. No. 10 Sampaguita St. De Castro Subd.  
Brgy. Santa Lucia Pasig City Metro Manila PH 1608

3<sup>rd</sup> Road Santa Cruz Brgy. Cannery Site  
Pololomolok South Cotabato PH 9504



**AVA KONSTRUKT**

**CREATING FLEXIBLE SPACE**

**LET'S CONNECT!**



**SCAN ME**